

Heavy Duty Industrial Warning Light



		AUM Series			
Model		AUM-A-125	AUM-B-125	AUM-A-150	AUM-B-150
Voltage		AC110V / AC220V / DC 12V / DC24			
Dimensions (mm)	Outdia	Ø125	Ø125	Ø147	Ø147
	Height	184	184	216	216
	Depth	176	230	205	260
Material		Body [AL], Ring [CU], Globe [GPPS / PC]		Body [AL], Ring [CU], Globe [GPPS]	
Light source & Operation	Bulb Revolving	•	•	•	•
	Multiple Function LED	•	•	•	•
	Caution LED	•	•	•	•
Mounting structure		Direct mounted			
Cable entry		Cable Glands 15			
Customization		Protective net , High luminance LED		Protective net , High luminance LED	
Page		p.72	p.72	p.73	p.73

Warning Light & Electronic Horn Combinations for Heavy Industry Applications



		AUCS Series		AUMS Series	
Model		AUCS 25W	AUCS 50W	AUMS-125	AUMS-150
Voltage		AC110V / AC220V / DC 12V / DC24			
Dimensions (mm)	Outdia	153	153	119	150
	Height	253	253	220	220
	Depth	245.5	327.6	435	470
Material		Body [AL], Globe [GPPS / PC], Electronic Horn [ABS resin]			
Timbre & Volume	Melody	Basic 3 sounds Max. 115 dB		Basic 3 sounds Max. 115 dB	
	Buzzer				
	Siren				
Light source & Operation	Bulb Revolving	•	•	•	•
	Multiple Function LED	•	•	•	•
	Caution LED	•	•	•	•
Mounting structure		Direct mounted		Wall mounted	
Cable entry		#16 zinc connector		Cable Glands 15	
Customization				High luminance LED	
Page		p.75		p.77	
				Protective net, High luminance LED	
				p.78	



AUM - A-R150
(With protective net option)

Nomenclature

AUM –	①	–	②
	Type		Warning Light Model
A type			R125/150 : Bulb Revolving(Ø125 /Ø150)
B type			L125/150 : Multiple Function LED (Ø125 /Ø150)
			CL125 : Caution LED (Ø125)

Heavy duty industrial Warning / Caution LED

- ⊙ The body is aluminum housing structure with strong shock resistance and excellent corrosion resistance.
- ⊙ 2 types of housings depending on installation purpose
- ⊙ Suitable for ships and heavy industries
- ⊙ Install the terminal block in the product or in the terminal box
- ⊙ Material : **Body** [AL 7 types A AC7A], **Ring** [CU], **Globe** [GPPS , PC (125mm LED & Caution LED)]
- ⊙ Standard body color : MUNSELL NO. 7.5G / 7.2
- ⊙ Operating Temperature : -25 ~ 50°C

AUM Series Common Specifications

1 Housing

- ⊙ 2 housing types depending on use A / B



AUM - A	AUM - B
<ul style="list-style-type: none"> ⊙ Basic housing type without attached terminal box ⊙ Suitable for installation in narrow spaces or on ceilings 	<ul style="list-style-type: none"> ⊙ A terminal box is attached to the housing ⊙ Convenient line connection with the terminal box

2 A Variety of Selectable Light Source & Function Combinations

Light Source & Function	Globe Outer Diameter
 Bulb Revolving	 125 mm
 Multiple Function LED steady / flashing / revolving / flashing-revolving	 150 mm
 Caution LED	 125 mm

3 Protective Net

- ⊙ Protective net is installed at the outside of the globe to prevent damage by shock (Protective net is optional)



4 Fully enclosed structure

- ⊙ The tightly sealed warning light structure is waterproof and dustproof

5 High luminance type

- ⊙ High luminance type is available for Multiple Function LED and Caution LED providing excellent radiant effect

6 Cable entry

- ⊙ Basic housing type without attached terminal box



AUM-A-R125

AUM-B-R125



AUM-A-L125

AUM-B-L125



AUM-A-CL125

AUM-B-CL125

Technical Diagram Unit: mm

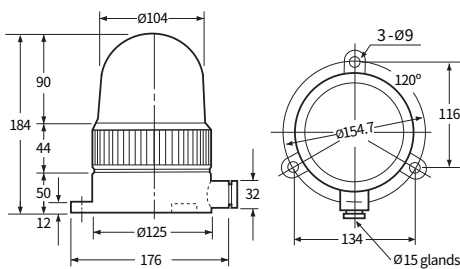

AUM - A - 125

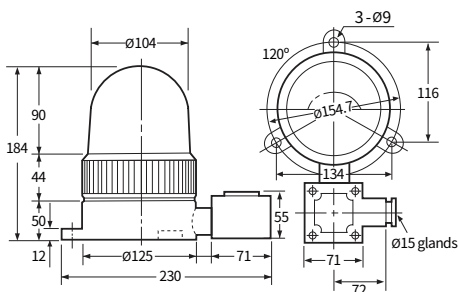

AUM - B - 125

AUM - A / B - R125 Bulb Revolving

- ⊙ Ø125mm, heavy duty industrial Bulb Revolving Warning light
- ⊙ Rev. count : Randomly controlled (130-140)

MODEL	Voltage	Current	Bulb	Weight		Color
				A	B	
AUM-A-R125 & AUM-B-R125	AC110V	0.11(A)	12V 15W	1687g	2220g	<ul style="list-style-type: none"> ● Red (R) ● Yellow (Y) ● Green (G) ● Blue (B)
	AC220V	0.06(A)	12V 15W	1687g	2220g	
	DC12V	1.19(A)	12V 15W	1125g	1658g	
	DC24V	0.74(A)	24V 15W	1125g	1658g	

AUM - A / B - L125 Multiple Function LED

- ⊙ Ø125mm, heavy duty industrial Multiple Function LED Warning light
- ⊙ 2 types of LED brightness : standard and high luminance
- ⊙ Rev. count : Randomly controlled

MODEL	Voltage	Current	LED EA	Weight		Color
				A	B	
AUM-A-L125 & AUM-B-L125	AC110V	0.09(A)	54EA	1337g	1877g	<ul style="list-style-type: none"> ● Red (R) ● Yellow (Y) ● Green (G) ● Blue (B)
	AC220V	0.04(A)	54EA	1337g	1877g	
	DC12V	0.26(A)	54EA	1047g	1683g	
	DC24V	0.32(A)	54EA	1055g	1691g	
High luminance	AC110V	0.11(A)	90EA	1360g	1897g	<ul style="list-style-type: none"> ● Red (R) ● Yellow (Y) ● Green (G) ● Blue (B)
AUM-A-L125H & AUM-B-L125H	AC220V	0.06(A)	90EA	1360g	1897g	
	DC12V	0.43(A)	90EA	1070g	1703g	
	DC24V	0.51(A)	90EA	1078g	1711g	

AUM - A / B - CL125 Caution LED

- ⊙ Ø125mm, heavy duty industrial Caution LED Warning light

MODEL	Voltage	Weight	Color
AUM-A-CL125	AC110V	1712g	<ul style="list-style-type: none"> ● Red (R) ● Yellow (Y) ● Green (G) ● Blue (B)
	AC220V	1695g	
	DC12V	1735g	
	DC24V	1735g	
AUM-B-CL125	AC110V	1712g	<ul style="list-style-type: none"> ● Red (R) ● Yellow (Y) ● Green (G) ● Blue (B)
	AC220V	1695g	
	DC12V	1735g	
	DC24V	1735g	



AUM - A/B-150 Series

Heavy Duty Industrial Warning Light



AUM-A-R150
(+보호망)



AUM-B-R150



AUM-A-L150



AUM-B-L150



AUM - A / B - R150 Bulb Revolving

- ⊙ Ø150mm, heavy duty industrial Bulb Revolving Warning light
- ⊙ Rev. count : Randomly controlled (130-140)

MODEL	Voltage	Current	Bulb	Weight		Color
				A	B	
AUM-A-R150 & AUM-B-R150	AC110V	0.11(A)	12V 15W	2974g	3206g	<ul style="list-style-type: none"> ● Red (R) ● Yellow (Y) ● Green (G) ● Blue (B)
	AC220V	0.06(A)	12V 15W	2974g	3206g	
	DC12V	1.19(A)	12V 15W	2407g	2640g	
	DC24V	0.74(A)	24V 15W	2407g	2640g	
High luminance	AC110V	0.31(A)	12V 35W	3000g	3232g	<ul style="list-style-type: none"> ● Red (R) ● Yellow (Y) ● Green (G) ● Blue (B)
AUM-A-R150H & AUM-B-R150H	AC220V	0.04(A)	12V 35W	3000g	3232g	
	DC12V	0.26(A)	12V 35W	2433g	2666g	
	DC24V	1.62(A)	24V 35W	2433g	2666g	



AUM - A / B - L150 Multiple Function LED



- ⊙ Ø150mm, heavy duty industrial Multiple Function LED Warning light
- ⊙ 2 types of LED brightness : standard and high luminance
- ⊙ Rev. count : Randomly controlled

MODEL	Voltage	Current	LED EA	Weight		Color
				A	B	
AUM-A-L150 & AUM-B-L150	AC110V	0.09(A)	54EA	2150g	2902g	<ul style="list-style-type: none"> ● Red (R) ● Yellow (Y) ● Green (G) ● Blue (B)
	AC220V	0.04(A)	54EA	2150g	2902g	
	DC12V	0.26(A)	54EA	1858g	2610g	
	DC24V	0.32(A)	54EA	1866g	2618g	
High luminance	AC110V	0.11(A)	90EA	2170g	2922g	<ul style="list-style-type: none"> ● Red (R) ● Yellow (Y) ● Green (G) ● Blue (B)
AUM-A-L150H & AUM-B-L150H	AC220V	0.06(A)	90EA	2170g	2922g	
	DC12V	0.43(A)	90EA	1878g	2630g	
	DC24V	0.51(A)	90EA	1886g	2638g	

Technical Diagram

Unit: mm

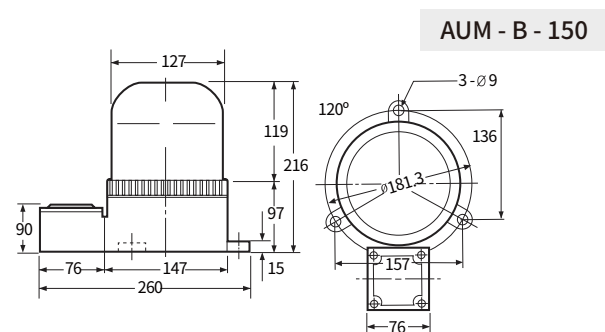
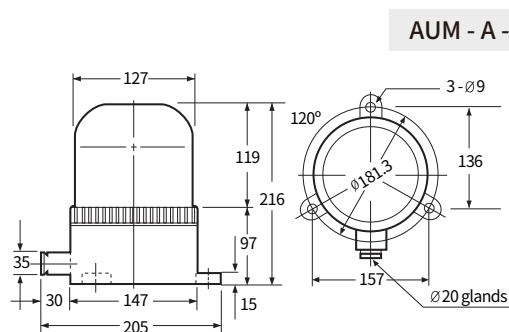



AUCS Series

Warning Light & Electronic Horn Combinations for Heavy Industry Applications



Nomenclature

AUCS	-	①	-	②	-	③	-	④
Ø125	Warning Light Model		High luminance	Output				Timbre
R125 : Bulb Revolving		No indication :		25W		AS : Siren		
L125 : Multiple Function LED		Standard Type		50W		AM : Melody		
CL125 : Caution LED		H : High luminance				AB : Buzzer		

Warning Light and Electronic horn combinations with excellent durability and perfectly enclosed structure, designed for heavy industry applications

- ⊙ Heavy duty industrial 125mm Warning Light and Electronic Horn
- ⊙ 3 types of light sources can be chosen, based on installation purpose
- ⊙ Suitable for outdoor, shipping, and heavy industry with completely waterproofed structure
- ⊙ Classified into one-way (25W) / two-way (50W), depending on output
- ⊙ Material : **Body** [Aluminum 7 types A AC7A], **Globe** [GPPS, PC]
Electronic Horn [ABS resin]
- ⊙ Standard body color : MUNSELL NO. 7.5G / 7.2
- ⊙ Operating Temperature : -25 ~ 50°C

AUCS Series Common Specifications

1 Light Source & Function



Bulb Revolving



Multiple Function LED

steady / flashing-revolving / flashing / revolving



Caution LED

3 Max. Output & Horn Direction

- ⊙ One-way Horn : 25W / Two-way Horn : 50W

4 Fully enclosed structure

- ⊙ Highly durable aluminum housing is excellent waterproofing and dust-proofing

2 Horn Sound Selection

- ⊙ 3 kinds of timbres : siren sounds, melody sounds, and buzzer sounds are available for the use

Channel	Basic timbre (3 sounds)	
CH1	Siren AS	Fire
CH2		Emergency
CH3		Urgent
CH1	Melody AM	The Magic Flute
CH2		Home Sweet Home
CH3		Fur Elise
CH1	Buzzer AB	bee bee bee bee
CH2		Ding dong
CH3		bee~bee~bee~

Technical Diagram

Unit: mm

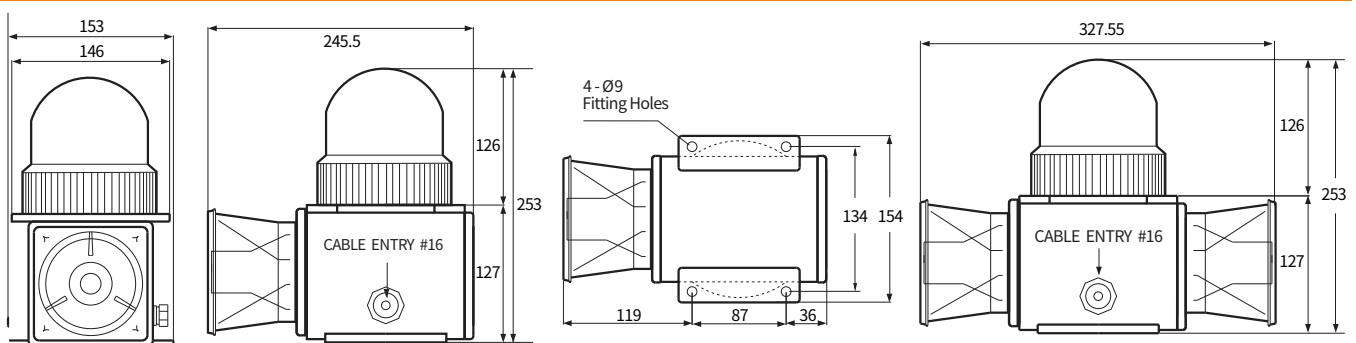



AUCS Series

Warning Light & Electronic Horn Combinations for Heavy Industry Applications



AUCS Series - 25W



AUCS - R125

Bulb Revolving Warning Light & Electronic Horn



- Heavy Duty Industrial Bulb Revolving Warning Light & Electronic Horn Combinations (Ø125mm)

Model	Voltage	Current	Sound & volume	Bulb	Weight	Color
AUCS-R125 25W (One-Way)	AC110V	0.21(A)	Siren AS / Max. 115 dB Fire / Emergency / Urgent	12V 15W	3760g	● Red (R)
	AC220V	0.12(A)		12V 15W		
	DC12V	1.50(A)	Melody AM / Max. 115 dB The Magic Flute Home Sweet Home Fur Elise	12V 15W	3697g	● Yellow (Y)
	DC24V	0.90(A)		24V 15W	3735g	
AUCS-R125 50W (Two-Way)	AC110V	0.26(A)	Buzzer AB / Max. 115 dB bee bee bee bee Ding dong bee~bee~bee	12V 15W	4659g	● Green (G)
	AC220V	0.17(A)		12V 15W		
	DC12V	1.64(A)	12V 15W	4594g	● Blue (B)	
	DC24V	0.98(A)	24V 15W	4594g		



AUCS Series - 50W



AUCS-L125

Multiple Function LED Warning Light & Electronic Horn



- Heavy Duty Industrial Multiple Function LED Warning Light & Electronic Horn Combinations (Ø125mm)
- 2 types of LED brightness: standard and high luminance

Model	Voltage	Current	Sound & volume	LED EA	Weight	Color
AUCS-L125 25W (One-Way)	AC110V	0.17(A)	Siren AS / Max. 115 dB Fire / Emergency / Urgent	54EA	3390g	● Red (R)
	AC220V	0.11(A)		54EA		
	DC12V	0.47(A)	Melody AM / Max. 115 dB The Magic Flute Home Sweet Home Fur Elise	54EA	3097g	● Yellow (Y)
	DC24V	0.45(A)		54EA	3105g	
AUCS-L125 50W (Two-Way)	AC110V	0.22(A)	Buzzer AB / Max. 115 dB bee bee bee bee Ding dong bee~bee~bee	54EA	4272g	● Green (G)
	AC220V	0.14(A)		54EA		
	DC12V	0.61(A)	54EA	3979g	● Blue (B)	
	DC24V	0.56(A)	54EA	3987g		

Customization

- Basic mounting for cable entry is #16 zinc connector, which can be changed to a cable gland through user specifications



AUCS-CL125

Caution LED Warning Light & Electronic Horn



- Heavy Duty Industrial Caution LED Warning Light & Electronic Horn Combinations (Ø125mm)

MODEL	Voltage	Sound & volume	Weight	Color
AUCS-CL125 25W (One-Way)	AC110V	Siren AS / Max. 115 dB Fire / Emergency / Urgent	3091g	● Red (R)
	AC220V			
	DC12V	Melody AM / Max. 115 dB The Magic Flute Home Sweet Home Fur Elise	3079g	● Yellow (Y)
	DC24V			
AUCS-CL125 50W (Two-Way)	AC110V	Buzzer AB / Max. 115 dB bee bee bee bee Ding dong bee~bee~bee	4112g	● Green (G)
	AC220V			
	DC12V	4085g	● Blue (B)	
	DC24V			



Nomenclature



AUMS	①	②	③	④
	Warning Light Model	High luminance	Output	Timbre
	R125/150 : Bulb Revolving	No indication :	25W	AS : Siren
	L125/150 : Multiple Function LED	Standard Type	35W	AM : Melody
	CL125 : Caution LED	H : High luminance		AB : Buzzer

Wall mounted Warning Light & Electronic Horn Combinations for Heavy Industry Applications



- Wall mounted model configured with heavy duty industrial integral Warning Light & Electronic Horn
- Timbre is changeable conveniently with the switch
- Suitable for outdoor, shipping, and heavy industry with completely waterproofed structure
- Convenient line connection with the terminal box
- Material : **Body** [Aluminum 7 types A AC7A] , **Globe** [GPPS, PC] , **Electronic Horn** [ABS resin]
- Standard body color : MUNSSELL NO. 7.5G / 7.2
- Operating Temperature : -25 ~ 50°C

AUMS Series Common Specifications

① A Variety of Selectable Light Source & Function Combinations

Light Source & Function	Globe Outer Diameter
 Bulb Revolving	 125 mm
 Multiple Function LED steady / flashing / revolving / flashing-revolving	 150 mm
 Caution LED	 125 mm

③ Protective Net

- Protective net option is available for Ø150mm globe models according to the user's needs

⑤ High Luminance Type

- High luminance type is available for excellent radiance effect

② Electronic Horn Sound Selection

- 3 kinds of timbres: siren sounds, melody sounds, and buzzer sounds are available for the use
- A switch attached at the outside to change timbre

Channel	Basic timbre (3 sounds)	
CH1	Siren AS	Fire
CH2		Emergency
CH3		Urgent
CH1	Melody AM	The Magic Flute
CH2		Home Sweet Home
CH3		Fur Elise
CH1	Buzzer AB	bee bee bee bee
CH2		Ding dong

④ Fully enclosed structure

- Highly durable aluminum housing is a perfectly enclosed structure with excellent waterproofing and dust-proofing.
- Convenient line connection with the terminal box installed at the bottom of the product



AUMS-125 Series

Warning Light & Electronic Horn Combinations for Heavy Industry Applications



AUMS-R125-25W



AUMS-R125

Bulb Revolving Warning Light & Electronic Horn



- ⊙ Heavy Duty Industrial Bulb Revolving Warning Light & Electronic Horn Combinations (Ø125mm)
- ⊙ Rev. count : Randomly controlled

Model	Voltage	Current	Sound & volume	Bulb	Weight	Color
AUMS-R125 25W (standard)	AC110V	0.21(A)	Siren AS / Max. 115 dB	12V 15W	4720g	● Red (R) ● Yellow (Y)
	AC220V	0.12(A)	Melody AM / Max. 115 dB	12V 15W		
	DC12V	1.50(A)	Buzzer AB / Max. 115 dB (See table below)	12V 15W	4153g	● Green (G) ● Blue (B)
	DC24V	0.87(A)		24V 15W		



AUMS-L125

Multiple Function LED Warning Light & Electronic Horn



- ⊙ Heavy Duty Industrial Multiple Function LED Warning Light & Electronic Horn Combinations (Ø125mm)
- ⊙ 2 types of LED brightness : standard and high luminance
- ⊙ 4 types of operation (steady / flashing / revolving / flashing-revolving) are available using a microchip
- ⊙ Rev. count : Randomly controlled



AUMS-L125-25W

Model	Voltage	Current	Sound & volume	LED EA	Weight	Color
AUMS-L125 25W (standard)	AC110V	0.17(A)	Siren AS / Max. 115 dB Fire / Emergency / Urgent	54EA	4250g	● Red (R)
	AC220V	0.11(A)		54EA		
	DC12V	0.48(A)	Melody AM / Max. 115 dB The Magic Flute Home Sweet Home Fur Elise	54EA	3957g	● Yellow (Y)
	DC24V	0.45(A)		54EA		
AUMS-L125H 25W (high luminance)	AC110V	0.19(A)	Buzzer AB / Max. 115 dB bee bee bee bee Ding dong bee-bee-bee~	90EA	4270g	● Green (G)
	AC220V	0.12(A)		90EA		
	DC12V	0.57(A)	90EA	3977g	● Blue (B)	
	DC24V	0.55(A)	90EA			4185g



AUMS-CL125

Caution LED Warning Light & Electronic Horn



- ⊙ Heavy Duty Industrial Caution LED Warning Light & Electronic Horn Combinations (Ø125mm)



AUMS-CL125-25W

MODEL	Voltage	Sound & volume	Weight	Color
AUMS CL125 -25W	AC110V	Siren AS / Max. 115 dB	4052g	● Red (R) ● Yellow (Y)
	AC220V			
	DC12V	Melody AM / Max. 115 dB	3452g	● Green (G) ● Blue (B)
	DC24V	Buzzer AB / Max. 115 dB		

Technical Diagram

Unit: mm

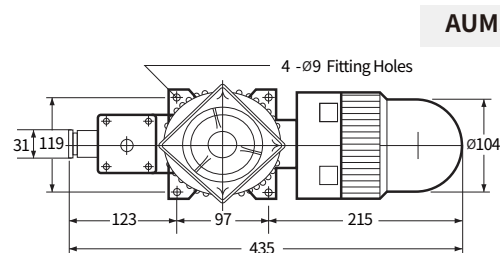
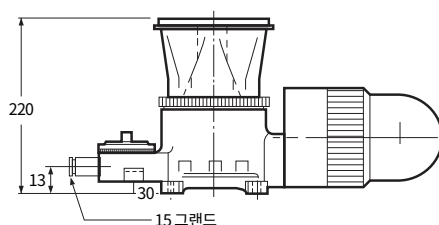



AUMS-150 Series

Warning Light & Electronic Horn Combinations for Heavy Industry Applications



AUMS-R150

Bulb Revolving Warning Light & Electronic Horn



- Heavy Duty Industrial Bulb Revolving Warning Light & Electronic Horn Combinations (Ø150mm)
- 2 types of LED brightness: standard and high luminance



AUMS-R150 -25W

Model	Voltage	Current	Sound & volume	Bulb	Weight	Color
AUMS-R150 25W	AC110V	0.21(A)	Siren AS / Max. 115 dB Fire / Emergency / Urgent	12V 15W	5290g	● Red (R)
	AC220V	0.12(A)		12V 15W		
	DC12V	0.50(A)	Melody AM / Max. 115 dB The Magic Flute Home Sweet Home, Fur Elise	12V 15W	4723g	● Yellow (Y)
				DC24V		
AUMS-R150H 25W	AC110V	0.22(A)	Buzzer AB / Max. 115 dB bee bee bee bee Ding dong bee~bee~bee~	12V 35W	5316g	● Green (G)
	AC220V	0.13(A)		12V 35W		
	DC12V	3.20(A)		12V 35W	4749g	● Blue (B)
				DC24V		



AUMS-L150

Multiple Function LED Warning Light & Electronic Horn



- Heavy Duty Industrial Multiple Function LED Warning Light & Electronic Horn Combinations (Ø150mm)
- 2 types of LED brightness: standard and high luminance



AUMS-L150 -25W

Model	Voltage	Current	Sound & volume	LED EA	Weight	Color
AUMS-L150 25W (standard)	AC110V	0.17(A)	Siren AS / Max. 115 dB Fire / Emergency / Urgent	54EA	4840g	● Red (R)
	AC220V	0.11(A)		54EA		
	DC12V	0.48(A)	Melody AM / Max. 115 dB The Magic Flute Home Sweet Home, Fur Elise,	54EA	4547g	● Yellow (Y)
				DC24V		
AUMS-L150H 25W (high luminance)	AC110V	0.19(A)	Buzzer AB / Max. 115 dB bee bee bee bee Ding dong bee~bee~bee~	90EA	4860g	● Green (G)
	AC220V	0.12(A)		90EA		
	DC12V	0.57(A)		90EA	4567g	● Blue (B)
				DC24V		

Technical Diagram

Unit: mm

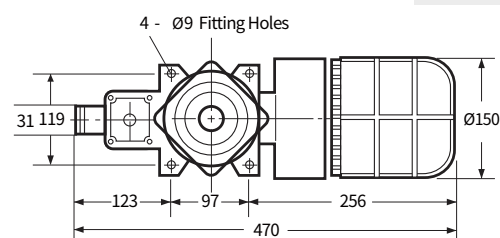
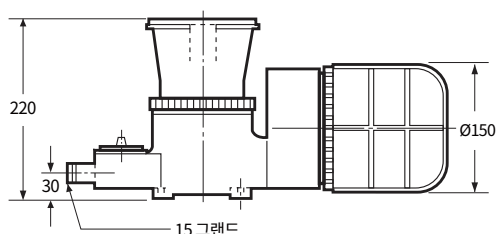

AUMS 150

Heavy Duty Industrial Warning Light & Electronic Horn Combinations



※ 150X310X210
Size model can be produced



		AUPS Series		
Model		AUPS-01	AUPS-02	AUPS-03
Voltage		AC110V / AC220V / DC12V / DC24		
Dimensions (mm)	Width	200	200	250
	Height	315	341	383
	Depth	250	250	310
Material		Globe [GPPS], Warning Light Body [ABS] Support [SUS], Electronic Horn [ABS]		Globe [GPPS, PC] Warning Light Body [SUS] Electronic Horn [ABS], Support [SUS]
Light source & Operation	Bulb Revolving	•	•	•
	Multiple Function LED	•	•	•
	Caution LED	•	•	•
Mounting structure		Wall mounted		Wall mounted
Customization		User selective customized		User selective customized Protective net
Page		p.82		

Customized Warning Light & Electronic Horn Combinations



		AUHP / H Series	
Model		AUHP-300 / H-500	
Voltage		AC110V / AC220V / DC12V / DC24 / DC48V	
Dimensions (mm)	Width	420	375
	Height	440	400
	Depth	200	200
Material		Globe [GPPS, PC] / Warning Light Body [ABS, SUS] / Body [SUS] / Electronic Horn [ABS]	
Customization		User customized manufacturing	
Page		p.83	



AUPS Series

Heavy Duty Industrial Warning Light & Electronic Horn Combinations



AUPS-01



AUPS-02



AUPS-03



AUPS series model can be combined according to The user's requirement

- Electronic Horn and Warning Light combination can be manufactured according to the user's selection
- The output of Electronic Horn is 25W,35W
- PS-01 : Ø100 Warning Light + Electronic Horn
PS-02 : Ø125 / Ø150 Warning Light + Electronic Horn
PS-03 : Ø125 heavy duty industrial Warning Light + Electronic Horn

AUPS-01

- Small Ø100 combined Warning Light + Electronic Horn

Technical Diagram

Unit: mm

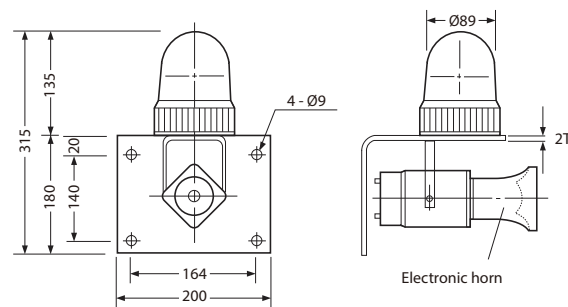

AUPS-02

- Standard Ø125 / Ø150 combined Warning Light + Electronic Horn

Technical Diagram

Unit: mm

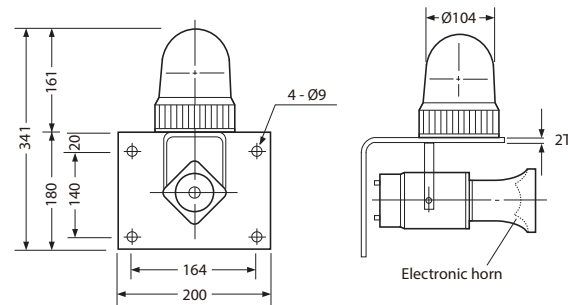

AUPS-03



- Heavy duty industrial Ø125 combined Warning Light + Electronic Horn
- Globe protective net option is available

Technical Diagram

Unit: mm

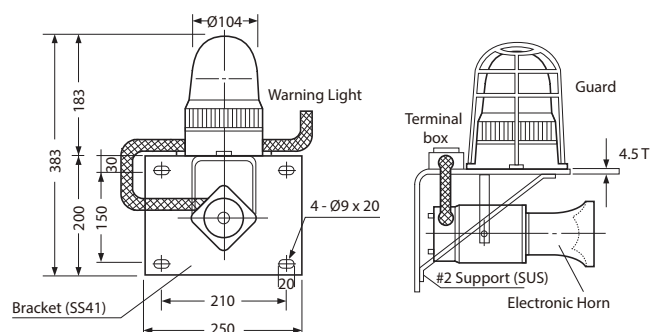

Warning Light Combination Model

Model	Warning Light Type	Ø	Warning Light
PS-01	Bulb Revolving	Ø100	AUW-R100 (P. 59)
	Multiple Function LED		AUW-L100 (P. 63)
	Caution LED		AUW-CL100 (P. 66)
PS-02	Bulb Revolving	Ø125	AUW-R125 (P. 59)
	Multiple Function LED	Ø150	AUW-R150S (P. 60)
			AUW-L125 (P. 64)*
			AUW-L150S (P. 65)*
	Caution LED	Ø125	AUW-CL125 (P. 66)
PS-03	Heavy duty industrial Bulb Revolving	Ø125	AUM-R125 (P. 74)
	Heavy duty industrial Multiple Function LED		AUM-L125 (P. 74)*
	Heavy duty industrial Caution LED		AUM-CL125 (P. 74)

* High luminance available model
(For more details about the Warning Light, see P. 56)



AU - HP Series

Special Order LED Warning Light & Electronic Horn



Special Order LED Warning Light & Electronic Horn

- Effectively usable with LED Warning Light and Electronic Horn integrated configuration
- From among LED Ø100 - Ø150 models, two can be combined
- Applicable for indicating device malfunction, material supply and stop signals, and signal transmission in automation line
- Consist of 8 channels usable according to the user's selection
- Volume is adjustable with external volume controller
- Please contact us to order optional products

Product Wiring Diagram

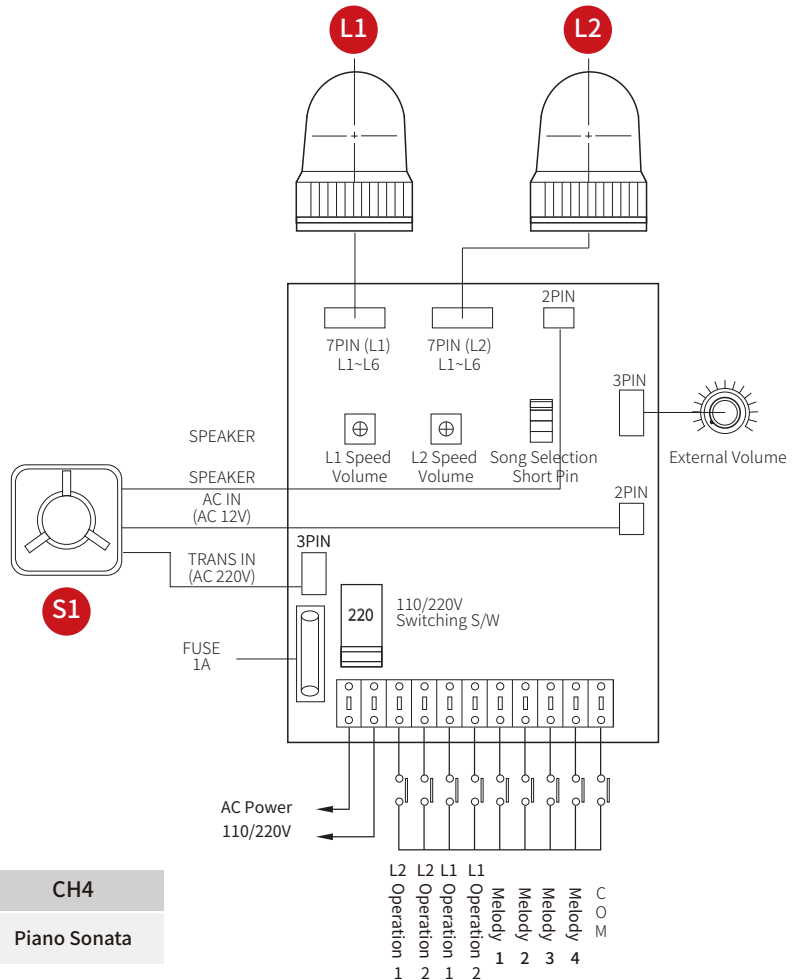

Product Combination Configuration

(See detailed specifications in p. 62 - 65)

Warning Light L1	Warning Light L2	Operation	Color
AUW-L100	AUW-L100	1 2	● Red (R)
AUW-L125	AUW-L125	Steady - Flashing	● Yellow (Y)
AUW-L150S	AUW-L150S	Flashing - Rotation	● Green (G)
Electronic Horn		AUP - EWH - 25W (P.69)	● Blue (B)

4 Melody Sounds

CH 1	CH 2	CH 3	CH 4
Home Sweet Home	Fur Elise	Turkish March	Piano Sonata

Technical Diagram

Unit: mm

